



SHANGHAI GRATING

Steel Bar Grating in China With 80 Years of U.S. Experience

Vantek Materials Limited
榮建行材料有限公司

Vantek Limited
榮建行有限公司
Est. 2000

Vincent Chung 鍾崇雲
Sales Manager

Mobile (852) 9631 4268

Tel (852) 2409 6999

Fax (852) 2419 0033

Email vincent@vantekmaterials.com

Website www.vantekmaterials.com

Unit 2305, 23/F, Tower 2,

Metroplaza, 223 Hing Fong Road,

Kwai Fong, N.T., Hong Kong.



Shanghai Grating

About Steel Bar Grating

Steel bar grating is an open grid assembly of steel bars in which the bearing bars, running in one direction, are spaced by rigid attachment to cross rods running perpendicular to the bearing bars.

The advantages of steel bar grating are many;

- Light weight
- High strength
- Durable
- Safety, slip resistant surfaces
- Custom fabricated panels for size, curves penetrations
- Design flexibility
- Openness
- Ventilation and light can pass through
- Self cleaning
- Reduced fire protection sprinklers (as permitted)
- Facilitates drainage

Steel bar grating's cost, weight, strength and openness offer advantages over other construction products including wood, solid steel plate, fiberglass, concrete and aluminum.

Application

Steel bar grating is used in power plants, petrochemical facilities, mining operations, industrial construction, ship building, paper mills, transportation (highways and rail), waste water treatment, metallurgical plants, communication facilities and other commercial, industrial and infrastructure projects.

Airplane unloading ramps	Freight car top walkways	Snow fences
Airport light guards	Ladder treads	Solar screens
Boat landing ramps and docks	Machine and motor bases	Stairs
Bridge centerline markers	Machinery safety guards	Stiles
Catwalks	Material screens	Strainers
Cracking plant trays	Mezzanine floors	Tote trays and boxes
Crating	Ornamental sign platforms	Tree and pole guards
Crow's nests	Paint booths	Trench covers
Dipping trays	Platforms	Truck beds
Drainage pit covers	Racks and shelving	Truck radiator grills
Fencing	Railway crossings	Vault covers
Fire escapes	Ramps	Ventilated bin floors
Floor boards	Refrigerator car trays	Ventilating screens
Flooring	Running boards	Walkways
Foot scrapers	Scaffolding	Wash racks
Freight car flooring	Security screens	Window and door guards



General Product Information	2
• Features	
• Quality Standards	
• Steel Grating Size	
Nomenclature	3
• Example	
Bearing Bar Spacing Series	4
• Series 1, 2 and 3	
Static Load and Deflection Table	5, 6, 7
• Series 1, 2, 3 Tables	
• Panel Width (mm)	
• Serrated Conversion Factors	
Manufacturing Tolerances	8
• Bearing Bar and Cross Rod Tolerances	
• Panel Tolerances	
Welding Standards	9
• Toe Plates	
• Banding	
Installation Clearances	9
• Panel to Panel Clearances and Cutout Clearances	
• Support Clearances	
Anchoring Details	10
• Anchor Options	
• Panel Attachments	
Stair Treads	11
• Stair Tread Configurations	
• Size and Attachment	
• Tolerances	
• Stair Tread Welding Standards	
Grates And Frames	12,13
Handrail Specification	14
Standard Stanchion Types	15
Glossary	16
• Welding Clip Installtion	
• Saddle Clip Installtion	
• Self-Tap Clip Installtion	
• I-Bar Material Information	
Saddle Clip Installation	17

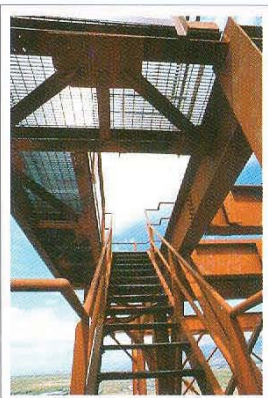

General Product Information



Features

- Panel size: 1m × 6m nominal standard (other size are available)
Material: Carbon structural steel (Stainless steel is available)
Finish: Mill finished, Hot dip galvanized, Painted
Surface: Plain bearing bares or Serrated bearing bars

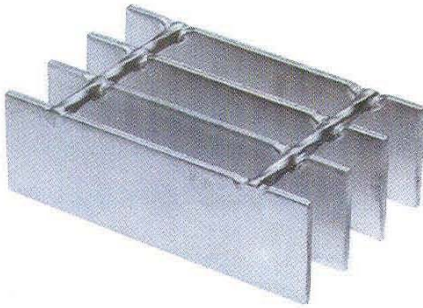

Plain Bearing Bars

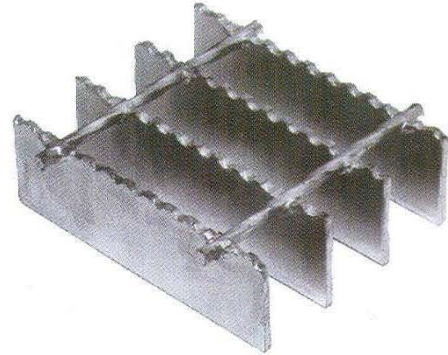

Serrated Bearing Bars

Quality Standards

Steel Grating Standard:	China YB-4001	U.S. NAAMM MBG531
Steel Standard:	China GB-700	U.S. ASTM A36
Hot Dip Galvanizing Standard:	China GB-2518	U.S. ASTM A123

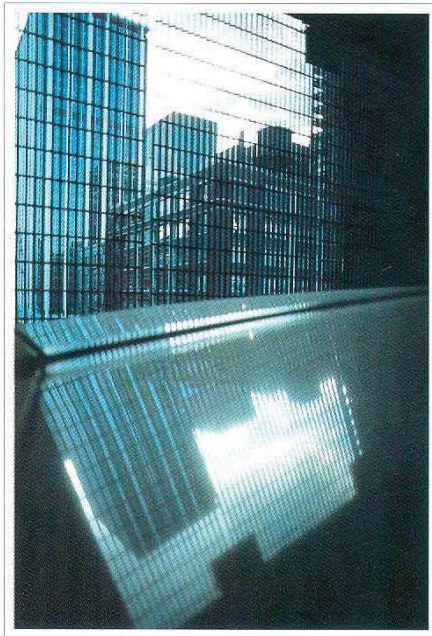

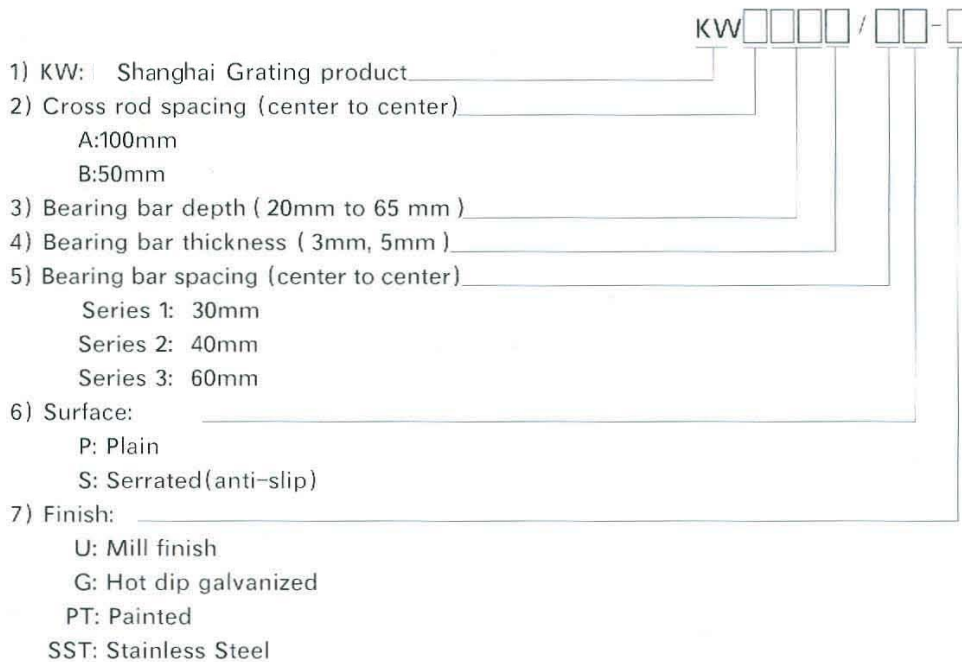

Example



Steel Grating Sizes

3mm Bar

Series	Bar Spacing (mm)	Cross Rod Spacing (mm)	Load Bearing Bar Size (width mm × thickness mm)			
			20 × 3	25 × 3	32 × 3	40 × 3
1	30	100	KWA203/1	KWA253/1	KWA323/1	KWA403/1
		50	KWB203/1	KWB253/1	KWB323/1	KWB403/1
2	40	100	KWA203/2	KWA253/2	KWA323/2	KWA403/2
		50	KWB203/2	KWB253/2	KWB323/2	KWB403/2
3	60	50		KWB253/3	KWB323/3	KWB403/3

5mm Bar

Series	Bar Spacing (mm)	Cross Rod Spacing (mm)	Load Bearing Bar Size (width mm × thickness mm)							
			20 × 5	25 × 5	32 × 5	40 × 5	45 × 5	50 × 5	55 × 5	65 × 5
1	30	100	KWA205/1	KWA255/1	KWA325/1	KWA405/1	KWA455/1	KWA505/1	KWA555/1	KWA655/1
		50	KWB205/1	KWB255/1	KWB325/1	KWB405/1	KWB455/1	KWB505/1	KWB555/1	KWB655/1
2	40	100	KWA205/2	KWA255/2	KWA325/2	KWA405/2	KWA455/2	KWA505/2	KWA555/2	KWA655/2
		50	KWB205/2	KWB255/2	KWB325/2	KWB405/2	KWB455/2	KWB505/2	KWB555/2	KWB655/2
3	60	50	KWB205/3	KWB255/3	KWB325/3	KWB405/3	KWB455/3	KWB505/3	KWB555/3	KWB655/3

Bearing Bar Spacing Series

Series 1

Series 1 has bearing bars spaced center-to-center at 30 mm. It is the most commonly used product for industrial applications. Since the strength of the grating is determined by the bearing bars, this spacing provides greater strength than the Series 2 or 3 with the same bearing bar size because of its closer spacing.

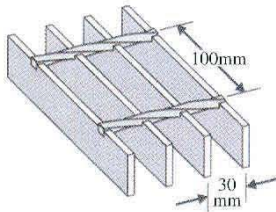

KWA Series 1
(30mm bearing bar spacing,
100 mm cross rod spacing)

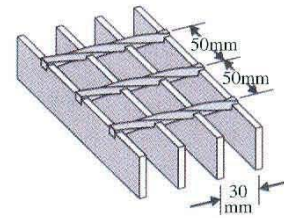

KWB Series 1
(30mm bearing bar spacing,
50 mm cross rod spacing)

Series 2

Series 2 has bearing bars spaced center-to-center at 40 mm. Series 2 grating is lighter weight and uses less material than Series 1. Series 2 is suitable for areas requiring shorter spans such as platforms, walkways, fencing and shelving.

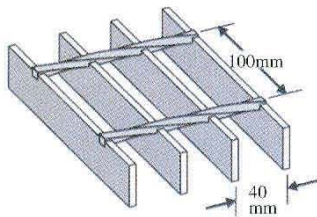

KWA Series 2
(40mm bearing bar spacing,
100 mm cross rod spacing)

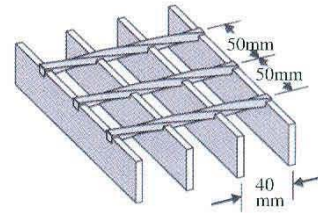

KWB Series 2
(40mm bearing bar spacing,
50 mm cross rod spacing)

Series 3

Series 3 has bearing bars spaced center-to-center at 60 mm. It is suitable for the mining industry and other applications where the wide spacing is a benefit. This series is also suitable for fencing. KWA, 100 mm cross rod spacing, is not recommended for series 3.

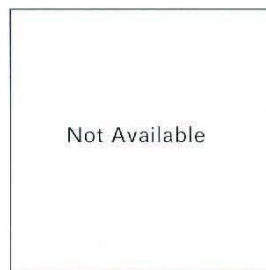

KWA Series 3
(60mm bearing bar spacing,
100 mm cross rod spacing)

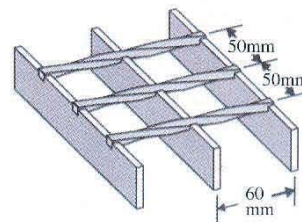

KWB Series 3
(60mm bearing bar spacing,
100 mm cross rod spacing)



Manufacturing Tolerances



Bearing Bar and Cross Rod Tolerances

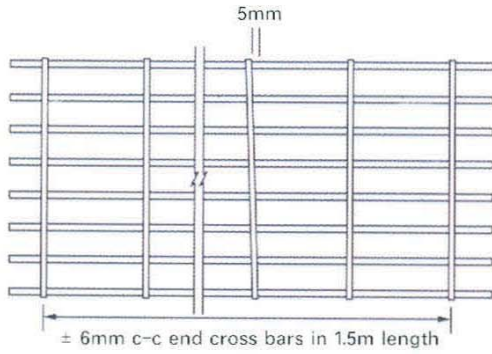

Cross Rod Spacing and Alignment

Cross rods should not vary more than 5 mm in either direction from perpendicular alignment with bearing bars. The tolerance of the cross bar spacing for 1,500 mm in length is ± 6 mm.

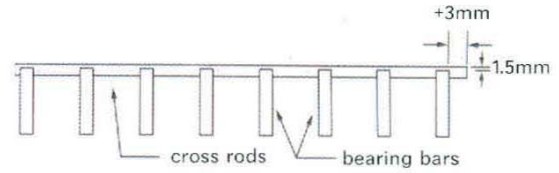

Cross Rod Position

The top of the cross rod should not project more than 1.5 mm above the top of the bearing bars and should not extend more than 3mm from side of bearing bars.

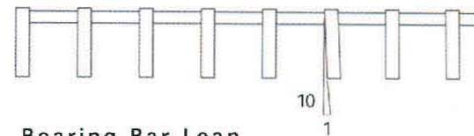

Bearing Bar Lean

Bearing bar lean must not exceed 1/10 of the depth of the bar.

Panel Tolerances

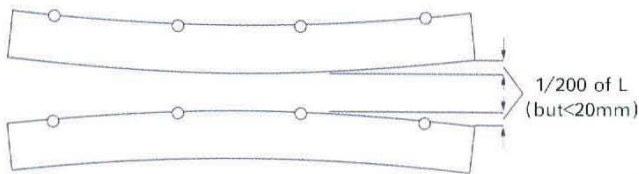

Longitudinal Bow

Longitudinal bow should be less than 1/200 of the length but less than 20 mm total.

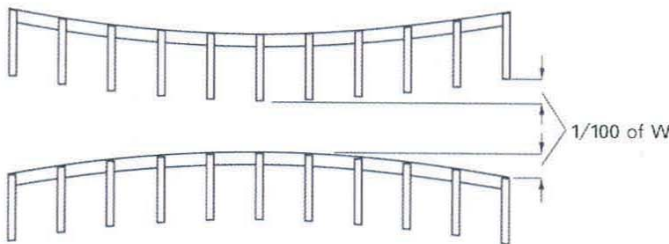

Transverse Bow

Before banding, the transverse bow should be less than 1/100 of the width.

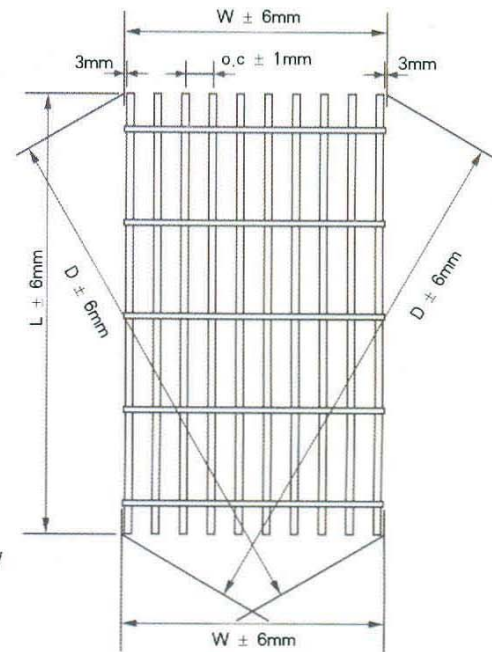

Overall Dimensions and Squareness

D = overall diagonal dimension
 W = length of cross rods including extensions outside of bearing bars
 L = length of bearing bars



Installation Clearances

Panel to Panel Clearances and Cutout Clearances

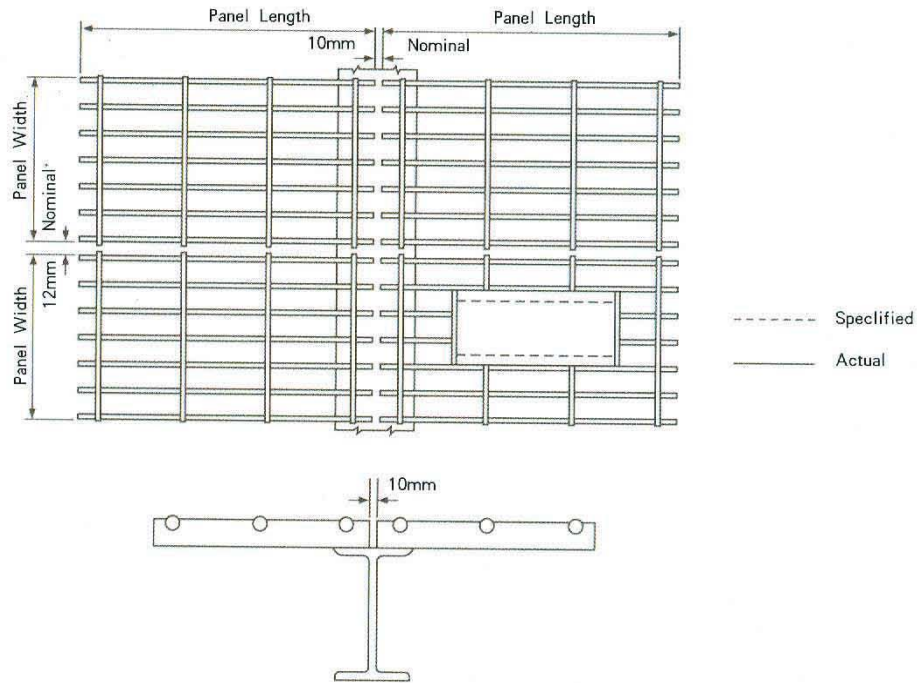

*12 mm nominal measured from panel bearing bars. Cross rods may extend 3 mm from bearing bars.

Support Clearances

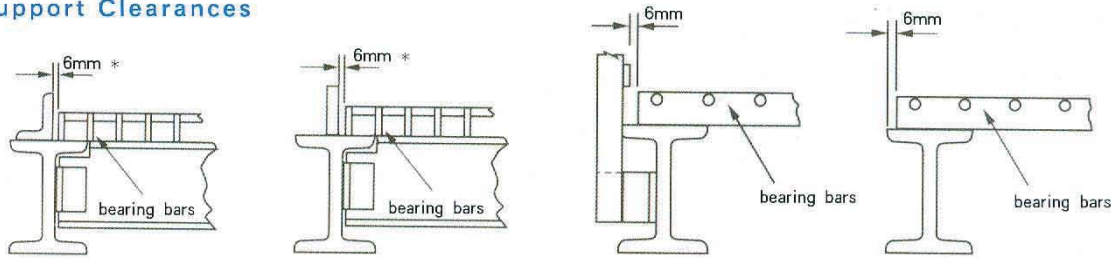

1-Beam and Angle Curb

1-Beam and Kickplate

1-Beam and Handrail

1-Beam

*6mm is recommended but dimension may vary due to bearing bar spacing. Dimension should not exceed bearing bar spacing.

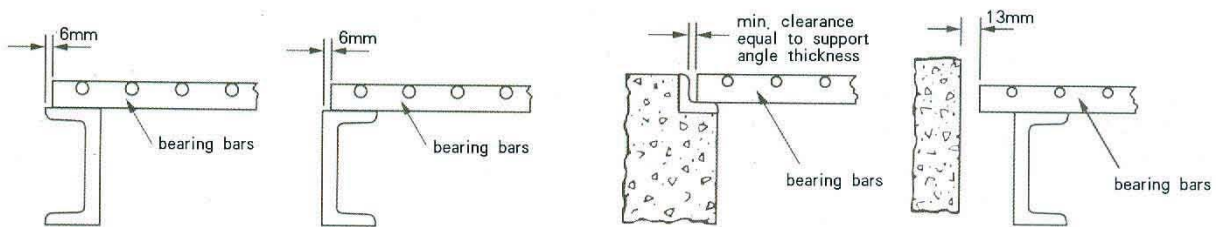

Channel Toed In

Channel Toed Out

Angle in Concrete

Channel and Concrete

Anchoring Details

Anchor Options

The recommended method of anchoring grating is to weld in place. Shanghai saddle clips also may be used to hold sections of open grating in place securely. These are removable and reusable when necessary. Stainless steel saddle clips are available at an increased price. Specify clips by size, material and quantity.

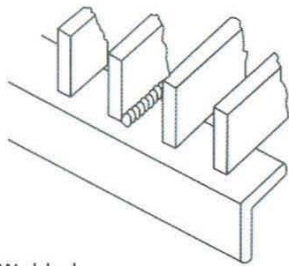

Welded

Used for permanently installed panels. Welds should be located as shown below. Welds should be 4 mm fillet welds, 20 mm long.

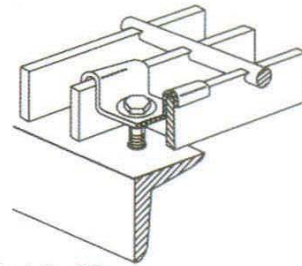

Saddle Clip

Used for installations where grating is subject to removal. Saddle clips are available for 30 and 40 mm bar spacing. Saddle clips should be located in same locations as welds in diagram below. Fastening accessories (self tapping screws) required for attachment of clips can be provided.

Panel Attachments

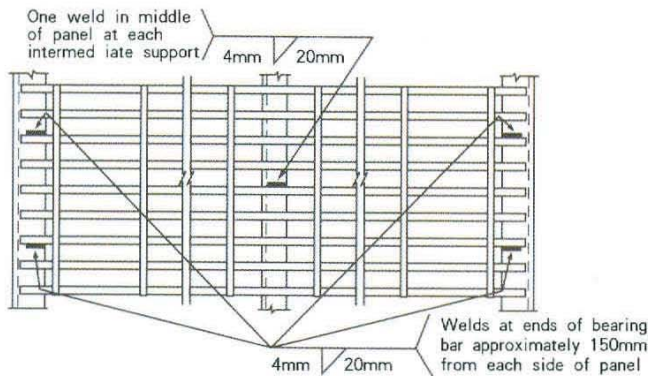

Attachment Locations

Attachments should be placed at intermediate support in the middle of panel and at the four bearing bar ends, 150 mm from each side of panel. Welds should be 4 mm fillet welds, 20 mm long.

Welding Standards

Toe Plates

Maximum depth of toe plate is $a+d$. It should not extend below the bearing bars. The minimum dimension for "a", the projection of toe plate above the grating, is 100 mm.

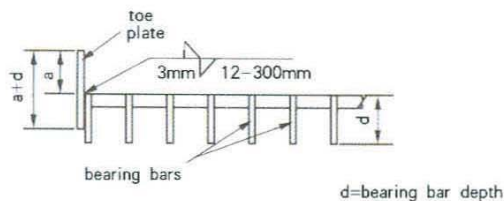

Attachment to Length of Bearing Bar

Toe plate to be welded with alternating 3 mm fillet welds, 12 mm long every 300 mm.

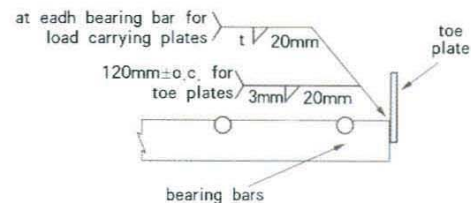

Attachment to End of Bearing Bars

Load carrying toe plates to be welded at each bearing bar with a fillet weld the size of the bearing bar thickness (t), 20 mm long. Non-load carrying toe plates to be welded to bearing bars with 3 mm fillet weld, 20 mm long every 120 mm.

Banding

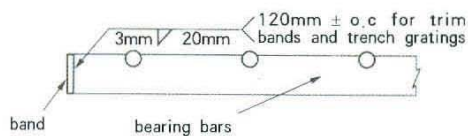

Standard Trim Band

End band to be welded with 3 mm fillet weld, 20 mm long every 120 mm.

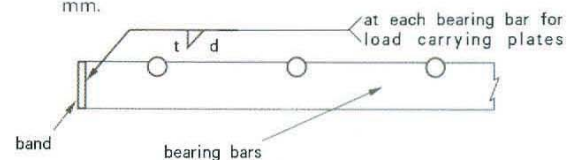

Load Banding (must specify)

Load carrying end band to be welded with fillet weld the size of bearing bar thickness (t) and the length of bearing bar depth (d) at each bearing bar.



Stair Tread Configurations



Tread	Nosing	Attachment to Stringer
WT1	No nosing	Welded to stringer. Both sides banded. Band size same as bearing bar.
WT2	No nosing	Bolted to stringer. Carrier plate size is 65mm × 5mm with holes for bolting.
WT3	Checkered plate nosing	Welded to stringer. Both sides banded. Band size same as bearing bar.
WT4	Checkered plate nosing	Bolted to stringer. Carrier plate size is 65mm × 5mm with holes for bolting.

Other abrasive nosing types are available upon request.

Size and Attachment

Recommended Stair Tread Widths (mm)

Tread Configuration	Series	Recommended Width with Nosing (mm)						
WT1	1	125	155	185	215	245	275	305
WT2		125	165	-	205	245	285	325
WT3		115	155	-	195	235	275	315
WT4		-	-	185	-	245	-	305
WT1	2	125	165	-	205	245	285	325
WT2		115	155	-	195	235	275	315
WT3	3	-	-	185	-	245	-	305
WT4		-	155	-	215	-	275	-

Maximum Stair Tread Length (mm)

Series	Max Length			
	25 × 3	25 × 5	32 × 5	40 × 5
Series 1	550	900	1300	1600
Series 2	450	750	1200	1500
Series 3	-	550	850	1350

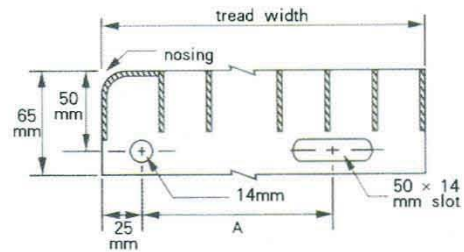

Bolt Hole Spacing for WT2 and WT4 (mm)

"A" (bolt hole centers)	45	75	75	100	100	150	150
-------------------------	----	----	----	-----	-----	-----	-----

Carrier Plates

Special carrier plates and holing are available on request. Carrier plate is 65mm × 5mm.

Tolerances

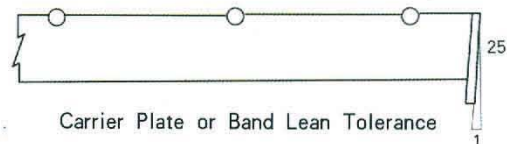
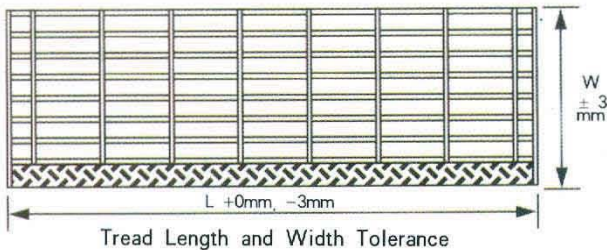

Stair Tread Welding Standards

Each carrier plate and bearing bar should be welded on one side of every load bearing bar with 3mm minimum fillet weld.

Handrail Specification

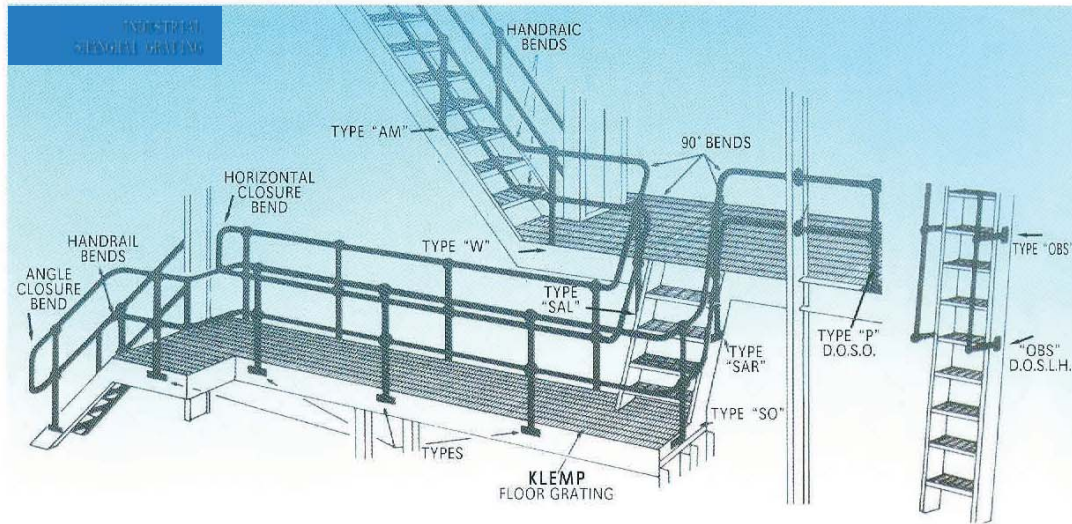

Unit: mm

Series	Type	Ball Size	Stanchion	Up Rail	Middle Rail	Height	
Serie 1 (Single)	Standard	KS/1	φ 66	φ 42.3	φ 33.5	Designed	
	Heavy Duty	KH/1	φ 76	φ 48.0	φ 42.3		
Serie 2 (Double)	Standard	KSa/2	φ 66	φ 42.3	φ 33.5	φ 26.8	1017
		KSb/2		φ 42.3	φ 33.5	φ 33.5	
	Heavy Duty	KHa/2	φ 76	φ 48.0	φ 42.3	φ 33.5	1017
		KHb/2		φ 48.0	φ 42.3	φ 42.3	
Serie 2 (Triple)	Standard	KSGa/2	φ 66	φ 42.3	φ 33.5	φ 26.8	1050
		KSGb/2		φ 42.3	φ 33.5	φ 33.5	
	Heavy Duty	KHGa/2	φ 76	φ 48.0	φ 42.3	φ 33.5	1050
		KHGb/2		φ 48.0	φ 42.3	φ 42.3	
Serie 3 (Triple)	Standard	KSa/3	φ 66	φ 42.3	φ 33.5	φ 26.8	1200
		KSb/3		φ 42.3	φ 33.5	φ 33.5	
	Heavy Duty	KHa/3	φ 76	φ 48.0	φ 42.3	φ 33.5	1200
		KHb/3		φ 48.0	φ 42.3	φ 42.3	

★ 1000,1200,1500mm Stanchion Distance Can Be Selected.

★ Handrail Height Can Be Designed By The Buyer.

★ K S a / 2



★ K H b / 3

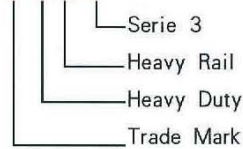



HORIZONTAL RAILS

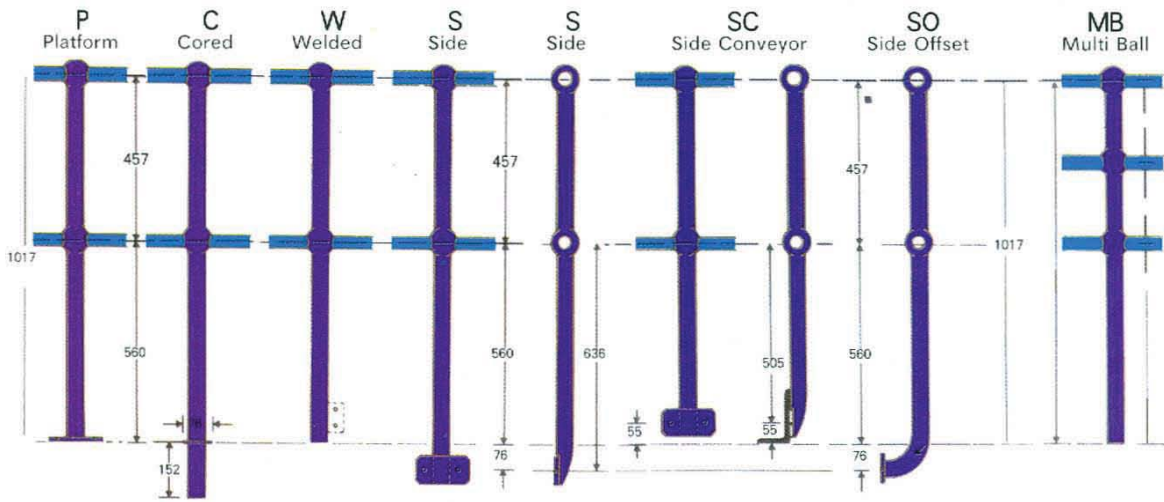

ANGLED RAILS

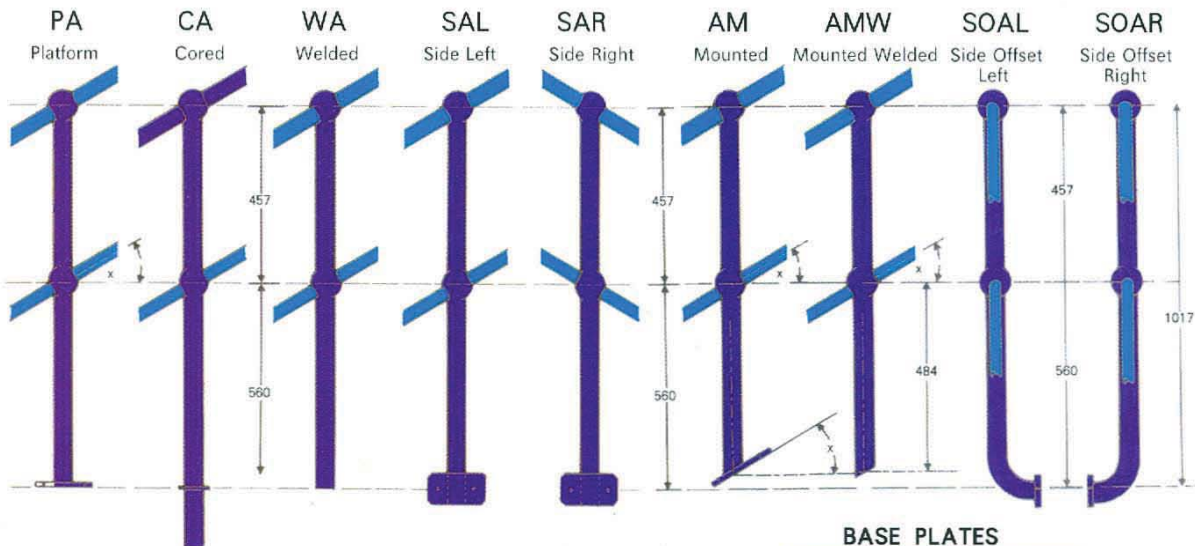

BASE PLATES

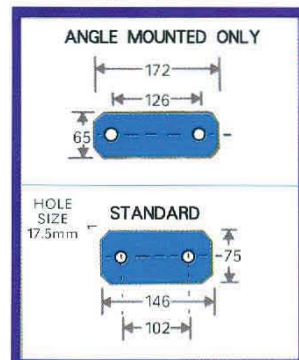

Glossory

Saddle Clip Installation use four grate clips to fasten panels up 10 feet long. For panels longer than 10 feet, two additional clips on each intermediate support are recommended.

Welding Clip Installation

- A. Chose the bolt length depend the height of grating. Welding bolt head on the steel support according to the drawings.
- B. Put the saddle clip fit on grating bars. Make the grating panel steady.

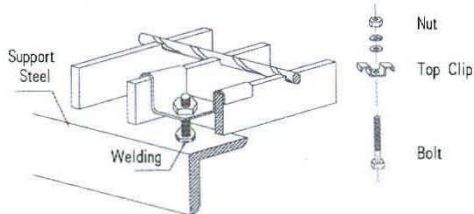

Self-Tap Clip Installation

- A. Assembly full set clips according to the drawings.
- B. Put the saddle clip fit on grating bars.
- C. Tighten the self-tap bolt on the support steel. Make the grating panel steady.

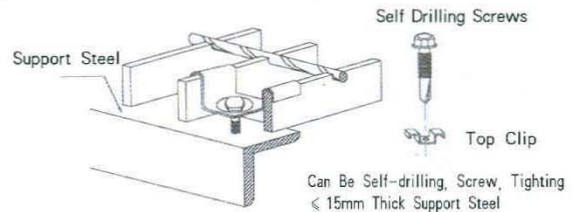

Saddle Clip Installation

- A. Assembly full set clips according to the drawings.
- B. Turn bottom clip 90°.
- C. Slip bottom clip between grating bars.
- D. Bottom clip snaps back, perpendicular to support clip. Clip bolt should be as close to support steel as possible.
- E. Saddle clip must be tightened in place by using a small torque wrench, a calibrated power tool or ratchet. Make the grating panel steady.

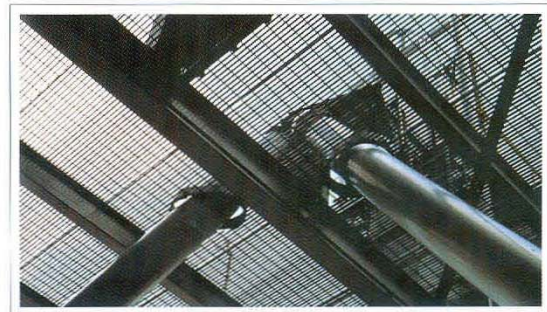
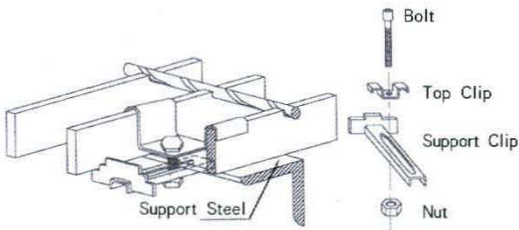

I-Bar Material Information

TYPE	I-Bar 25 × 5 × 3	I-Bar 32 × 5 × 3	I-Bar 38 × 5 × 3	I-Bar 44 × 5 × 3	I-Bar 50 × 5 × 3	I-Bar 50 × 7 × 4	I-Bar 55 × 7 × 4	I-Bar 60 × 7 × 4	I-Bar 65 × 7 × 4	I-Bar 75 × 7 × 4
I-Bar Size (mm)										
I-Bar Wt. (KG/M)	0.75	0.96	1.13	1.3	1.51	1.98	2.16	2.39	2.55	2.96
Moment Of Inertia(CM ⁴)	0.605	1.251	2.083	3.221	4.609	6.432	8.488	11.224	13.960	21.387
Panel Wt. (KG/M ²)	28.064	35.272	41.12	46.9	54.04	70.02	76.14	83.96	89.4	103.34
Grating Wt. (KG/M ²)	29.556	37.118	43.38	49.5	57.06	73.98	80.46	88.74	94.5	109.26



Ordering Information

When ordering shanghai steel bar grating be sure to specify:

1. KWA or KWB to indicate cross rod spacing (100 or 50 mm)
2. Depth and thickness of bearing bars (eg., 203, 325)
3. Series 1, 2 or 3 to indicate spacing of bearing bars (30, 40 or 60 mm)
4. P or S to indicate plain or serrated bearing bars
5. U, PT or G to indicate mill, Painted or hot dip galvanized finish
6. Length of span (length of bearing bars)
7. Width of panel
8. Extras (trim band, toe plate, nosing, etc.)
9. Type of anchors and size
10. Shipping instructions

When areas of grating are required, submit a sketch of the area to be covered and indicate:

1. Supporting structure
2. Edge of grating panel condition (installation clearances from structural supports)
3. Direction of span (parallel to bearing bars)
4. Dimensions of total area of grating

NAAMM Supplement

A supplement to this catalog containing information on NAAMM Standards for metal bar grating is available on request. There are differences between the YB-4001 and the NAAMM standard MBG-531.



Glossary of Terms

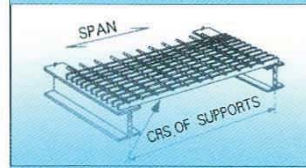

LOAD BAR (Bearing Bar)
Uniform load carrying bar spanning across supporting members.

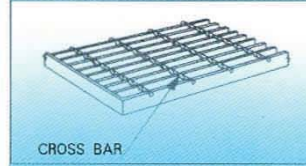

CROSS BAR (Twist Bar)
Uniform rod, in square twisted steel, forged into and at right angles to the load bar.

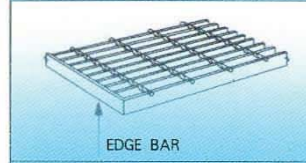

EDGE BAR (Banding Bar)
Trimming bar, generally of same size as and welded to ends of load bars across panel ends and around notches and penetrations (if any).

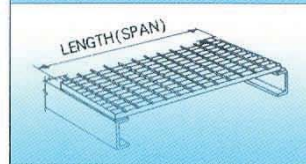

LENGTH OF PANEL (Span)
Overall dimension of a panel measured parallel with load bars. (Indicated by \leftarrow symbol).

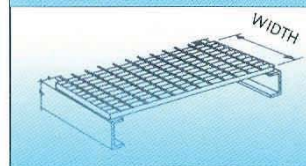

WIDTH OF PANEL
Overall dimension of a panel measured at right angles to the load bars. (Always called "Width" even if greater than the length.

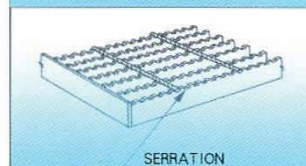

SERRATIONS
Small notches made in the top edge of the load bar to assist in skid resistance.



NOSING BAR
A member attached to or on the leading edge of a stair tread to assist in skid resistance.



KICK PLATE
Heavy section flat bar welded to ends of sides of panels and around cut-outs, etc., when specified. Top edge to be 100mm above grating generally.

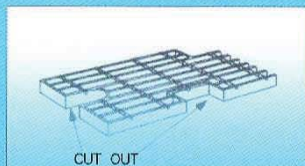

CUT OUTS
Grating areas removed from panel to permit passage or installation of pipes, plant, and structural and handrail items.

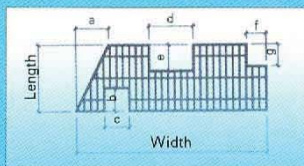

NETT AREA
The area of a panel ($W \times L$) excluding cutouts.

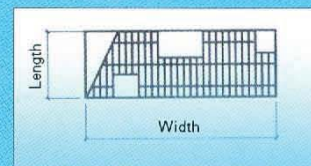

GROSS AREA
The total area of grating as shown on drawings using overall dimensions of grating including cutouts.

INDUSTRIAL
SHANGHAI GRATING



SHANGHAI ZHENKAN METAL
PRODUCTS CO., LTD.

8K New Shanghai City Square, 33
He Nan Road(S), Shanghai
200002, China

Phone: 86-21-5289-5720



Vantek Materials Limited
榮建行材料有限公司

Vantek Limited
榮建行有限公司
Est. 2000

Vincent Chung 鍾崇雲
Sales Manager

Mobile (852) 9631 4268
Tel (852) 2409 6999
Fax (852) 2419 0033 Unit 2305, 23/F, Tower 2,
Email vincent@vantekmaterials.com Metroplaza, 223 Hing Fong Road,
Website www.vantekmaterials.com Kwai Fong, N.T., Hong Kong.

kprc2-96